

Reaction of water with glass: influence of a transformed surface layer

R. H. DOREMUS, Y. MEHROTRA*

Materials Engineering Department, Rensselaer Polytechnic Institute, Troy, New York 12181, USA

W. A. LANFORD, C. BURMAN

Physics Department, State University of New York, Albany, New York 12222, USA

Profiles of hydrogen and glass constituents were measured by nuclear reaction techniques in a number of silicate glasses after hydration. The results were interpreted in terms of interdiffusion of alkali and hydronium ions, including the possibility of a transformed surface layer. Durable glasses such as a commercial soda-lime and caesium-alkali-lime glasses did not have a transformed layer, whereas less durable glasses, such as a soda-lime without alumina and a sodium-potassium-lime, did have a transformed surface layer. When a transformed layer is incorporated in the interdiffusion model, the diffusion coefficient of sodium calculated is the same as found in the dry glass.

1. Introduction

Mechanisms of the reaction of water with glass determine the long-term durability of glass for traditional applications and also for radioactive waste containment. Prediction of the state of a glass surface beyond experimental times requires knowledge of these mechanisms.

The first step in the reaction of water with an alkali silicate glass generally is assumed to be the exchange of alkali ions in the glass with hydrogen-bearing ions from the water:

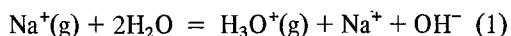

where g is the glass. There is evidence that the hydronium (H_3O^+) and alkali ions are the exchanging species [1]. In aqueous media the surface of the glass also dissolves into the water. This dissolution takes place by several succeeding reactions that break up the silicon-oxygen network:

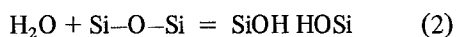

Alkali silicate glasses can be graded on a scale of durability depending upon how rapidly they react with water. More durable glasses such as commercial soda-lime silicates and certain mixed

alkali silicates react slowly with water, whereas some other alkali silicates react much more rapidly. Small variations in glass composition can change a glass from durable to non-durable. We propose that a likely difference between durable and less durable silicate glasses is that the latter have a layer on the glass surface after reaction with water that is transformed to a different structure. There is a variety of experimental evidence, which will be discussed in a later section, for this layer. It has, for example, been identified with low angle X-ray scattering [2]. One important property of the transformed layer is that ionic mobilities in it are much greater than in the dry glass, leading to more rapid reaction of water with glasses that develop the layer.

To examine the influence of a transformed layer on the kinetics of the reaction of water with glass, a number of different silicate glasses listed in Table I were studied after various hydration treatments. Glass number 1 is a soda-lime silicate that was one of the first successful glass electrodes (Corning 015 glass). It is less durable than most commercial soda-lime glasses, but is more durable than most binary alkali silicate glasses. This glass

*Present address: Optical Group, Perkins Elmer Corp., Norwalk, CT 06856.

TABLE I Batch compositions of glasses (mol %)

Oxide	Glass number						
	1*	2	3	4	5	6	7
SiO ₂	72.2	72.9	74.6	72.0	76.7	74.0	72.0
Na ₂ O	21.4	21.6	17.0	—	8.1	—	15.9
Li ₂ O	—	—	—	10.0	—	26.0	—
K ₂ O	—	—	—	—	9.1	—	0.1
Cs ₂ O	—	—	1.7	10.0	—	—	—
CaO	6.4	4.3	6.7	8.0	6.2	—	7.9
SrO	—	1.2	—	—	—	—	—

*Corning 015.

has been studied extensively. Wikby [3] showed by measurements of the electrical resistance of hydrated bulbs of glass 1 (his S₃) during etching that they have a series of surface layers of different resistivity: first a low resistance layer, then a high resistance layer, and then the “dry” glass of intermediate resistivity.

In the present study we hydrated the surfaces of the glasses (Table I) at different times and temperatures in water at neutral pH, and measured the profile of hydrogen in the surface from a resonant nuclear reaction [1]. Profiles of the other constituents of the glass were measured with Rutherford backscattering of helium ions. In this way a complete picture of the distribution of elements at the glass surface was obtained.

The reaction of water with glass can be described in terms of a model involving a moving surface boundary caused by dissolution of the glass [4], and by interdiffusion of two different ions, giving a concentration dependent diffusion coefficient [5]. In the present work a transformed layer in which ionic mobilities are high is included in the model, and this addition gives a satisfactory description of the experimental results of Wikby [3] and the profiles measured here.

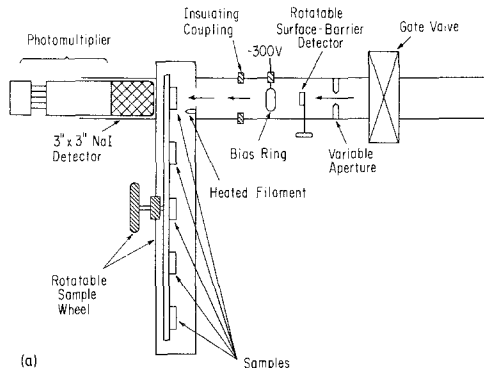

2. Experimental procedures

Glasses 1 to 6 were melted in platinum crucibles at about 1350° C for several hours, poured, and then annealed for up to 2 h (glasses 1 to 3 at 550° C, 4 and 5 at 600° C, 6 not at all). Glass number 7 was used as-received.

Slices of glasses 1 to 3 were cut with a low-speed diamond saw to 40 mm × 10 mm × 1 mm, and polished wet on both sides through 240, 320, 400 and 600 grit paper and 1 μm alumina slurry in water. Other glasses were cut to a convenient size (about 1 cm²) and the smooth as-cooled surface used. All samples were etched in 5% HF for 3 to 4 min and blow-dried cold before hydration to remove any hydrated layers formed during polishing or previous handling.

Hydration experiments were carried out in covered polymethyl pentene or polypropylene vessels, and the glass samples were supported on nylon grids on teflon rings. All plastic ware was soaked for 12 h at the experimental temperature before use. Glasses 1 to 3 were hydrated in 600 ml of a pH 5.5 tris/HCl buffer (MCB manufacturing Chemists) at 50° C or 90° C; the temperature was controlled to ±1° C by hot water in a jacket. Glasses 4 to 8 were hydrated in a large volume (several litres) of distilled water at 90° C that was renewed for long runs.

Hydrogen profiles in the surfaces of the hydrated glasses were measured with the resonant nuclear reaction

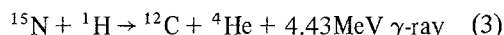

A glass target about 1 cm² was bombarded with a beam of ¹⁵N ions from the Dynamitron linear accelerator at SUNY, Albany. The target arrangements are shown in Fig. 1. The yield of γ-rays was measured with a sodium iodide scintillation counter. In some experiments the samples were mounted on a column at 45° to the incident beam.

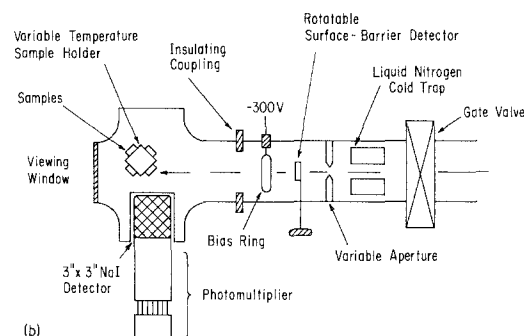

Figure 1 Experimental arrangement for nuclear reaction analysis of (a) room temperature (b) frozen samples.

The column was cooled with a mixture of dry ice and alcohol to prevent loss of water in the vacuum system. To measure the profile, the beam energy was raised in steps of 0.1 MeV above the energy needed to induce the nuclear reaction between ^{15}N and hydrogen (the resonance energy). At higher energies the beam penetrates the glass and loses energy; when the energy is again the resonance value reactions with hydrogen atoms occur and the number of γ -rays produced is proportional to their concentration at this depth. Thus by measuring the yield of characteristic γ -rays against ^{15}N energy, the depth profile of hydrogen in the glass is determined (see [1] and [6] for more details of this method).

Profiles of elements other than hydrogen in the glass were measured with Rutherford backscattering with the chambers shown in Fig. 1. A monoenergetic beam of ^4He ions of area 5 mm^2 and current 15 to 20 namp bombarded the target at 2 MeV energy. Backscattered ions were analysed with a silicon surface barrier detector at approximately 180°C from the incident beam, and the detector output was amplified and analysed for the energy spectrum with a multichannel analyser. A typical plot of counts as a function of energy is shown in Fig. 2, with different elements identified.

The steps in the counts against energy curve,

as labelled in Fig. 2, represent the maximum energies with which helium can be backscattered from the elements indicated. This maximum energy is determined entirely from two-body scattering kinematics. If helium scatters from an atom inside the glass, the helium loses energy both entering and leaving the glass, resulting in the step-shaped spectrum in Fig. 2. If any element is depleted from the surface region, the step for that element will shift to lower energies. This can be seen in Fig. 3 where an expansion of the sodium portion of superimposed spectra recorded for glass 1 (O15) exposed to water for different lengths of time. The thickness of the region depleted of sodium can be determined quantitatively by the shift in the sodium step.

In a few samples profiles of sodium, calcium and silicon were determined by etching layers of the hydrated glass surface with 0.2% HF in 0.1M HCl, and measuring the content of the etching solution with the atomic absorption spectrometer. The thickness of the layers removed was calculated from the weight change of the sample before and after etching and the estimated density of the hydrated layer. More experimental details are given by Mehrotra [7].

3. Experimental results

A number of hydrogen profiles for glass number 1

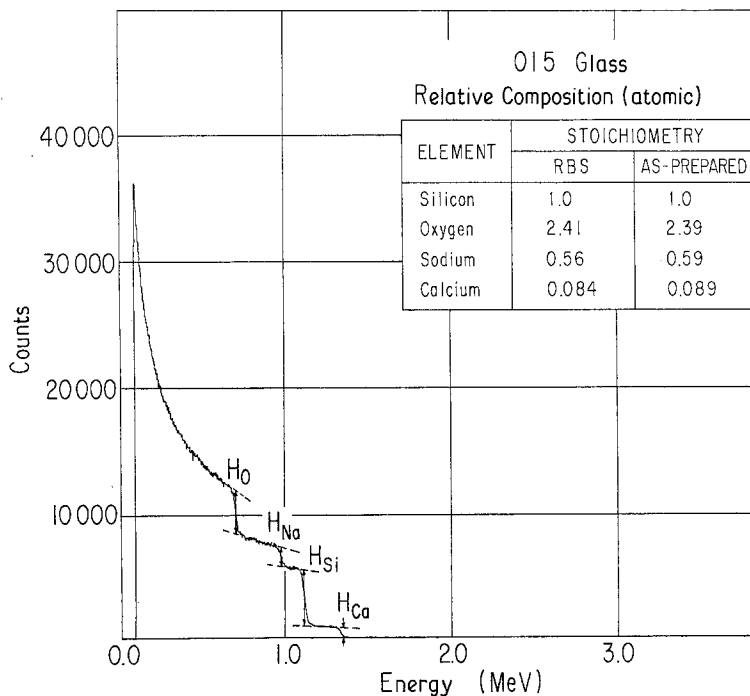

Figure 2 Rutherford backscattering spectrum of glass number 1. The step heights are proportional to atomic concentrations.

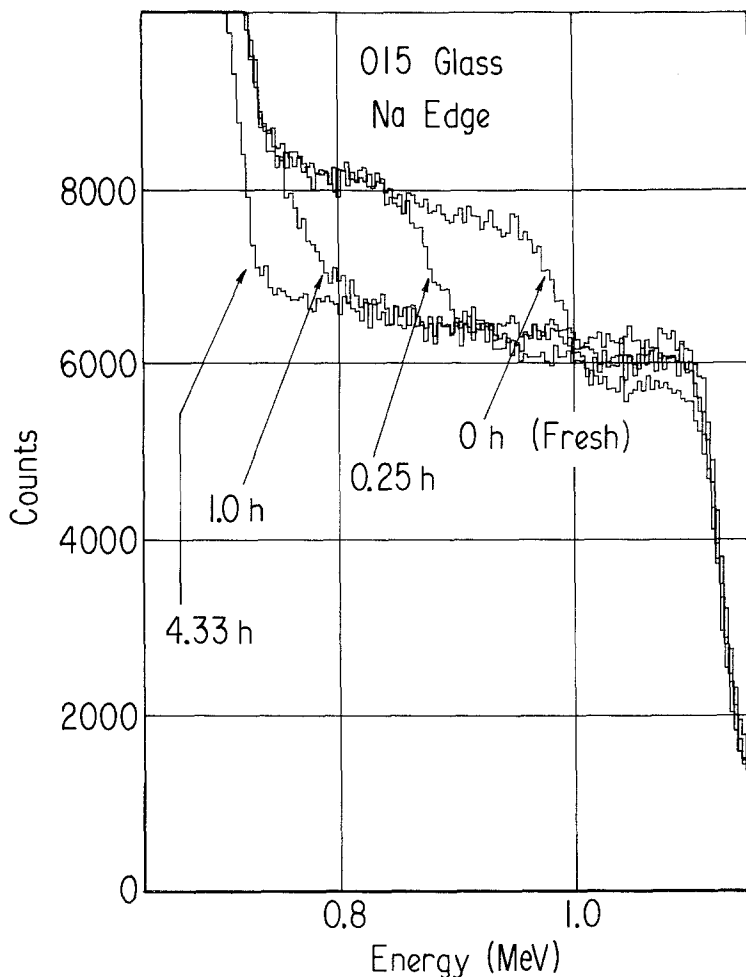

Figure 3 Enlargement of the sodium edge in Fig. 2 after different hydration times.

after various times of hydration at 90°C are shown in Fig. 4. The penetration depths are nearly proportional to the square root of the hydration time. In unfrozen samples the concentration of hydrogen decreases somewhat toward the surface. If the sample is frozen with dry ice—alcohol before the chamber is evacuated the profiles of Fig. 5 are found. The absolute level of hydrogen is about double that found for the frozen samples, and the hydrogen concentration is constant near the glass surface. It appears that some water is being pumped out of the glass in the unfrozen samples, reducing the hydrogen level. Therefore, the results for the frozen samples are more reliable.

Profiles of sodium in glass number 1 determined by Rutherford backscattering (Fig. 3) are shown in Fig. 6. No attempt has been made to separate the instrumental resolution from these data. See, for example, the measured profile of the untreated (fresh) sample. The depths of leaching to one half the original sodium concentration,

after subtraction of the value for the untreated sample, agree closely with penetration depths from the hydrogen profiles, as shown in Table II. Sodium depletion further than shown in the table could not be measured, because of interference from scattering from other atoms.

The preferential leaching of calcium from glass number 1 was much slower than for sodium, as shown in Table II and Fig. 7. These leaching depths imply an interdiffusion coefficient for the calcium—hydrogen exchange several thousand times smaller than for the sodium—hydrogen exchange.

Leaching depths of sodium in glass number 1 after hydration at 50° are also given in Table II. The ratio of interdiffusion coefficient at 90° to that at 50° is about 27, giving an activation energy of about 80 kJ mol^{-1} .

The ratio of hydrogen atom concentration to sodium atom concentration was an average of about 2.1 for glass number 1.

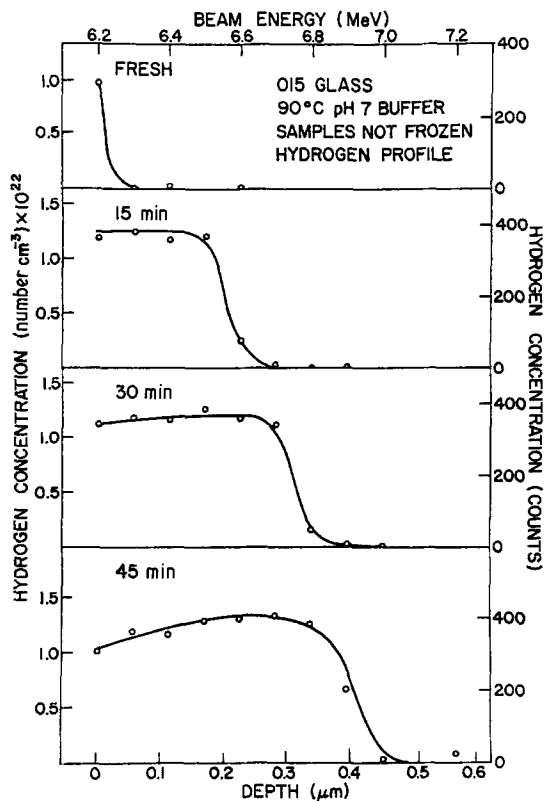

Figure 4 Profile of hydrogen concentration against distance into the glass for glass number 1 after hydration at 90°, at pH 7, from the nuclear resonant reaction. Sample at room temperature.

Surface profile depths after hydration of glasses 2 and 3 are also given in Table II. The hydrogen, sodium and calcium values for glass number 2 were similar to those for glass number 1; the slow leaching of strontium from glass number 2 was similar to that of calcium, as shown in Fig. 8. The hydrogen and sodium depths for glass number 3 were much less than for glasses 1 and 2, and imply an interdiffusion coefficient for hydrogen and sodium about 25 times smaller in this glass than in glasses 1 and 2. Preferential leaching of caesium from glass number 3 was not detectable after 2 h at 90°, as shown in Fig. 9, establishing that caesium leaching is much slower than for sodium. A profile of sodium in glass 3 determined by chemical etching and analysis is shown in Fig. 10.

For glasses 5 and 6 the depth of the hydrogen profile was 0.43 and 0.48 μm, respectively, after 30 min of hydration at 90° C. The depth for glass number 4 was 0.43 μm after 25.3 h of hydration at 90° C; the profile of hydrogen for this glass and treatment are shown in Fig. 11.

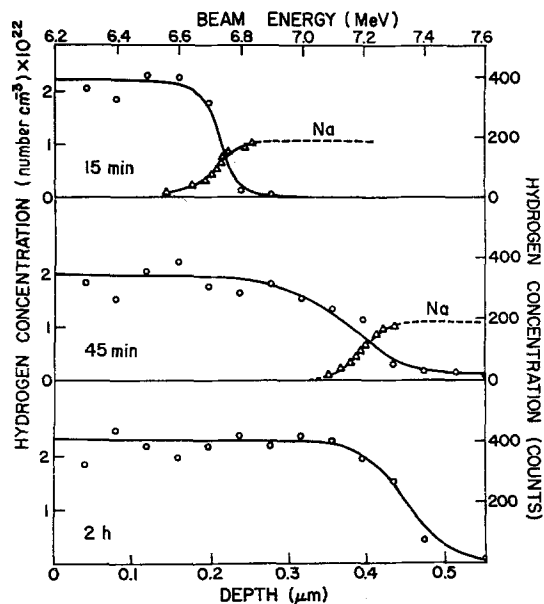

Figure 5 Profile of hydrogen concentration against distance into the glass for glass number 1, from the nuclear resonant reaction. Sample cooled below 0° C.

4. Interdiffusion with a transformed layer

A variety of independent experiments suggest that after reaction with water some silicate glasses develop layers on their surfaces in which the monovalent cations are more mobile, and which have an expanded structure.

1. Wikby [3] measured the resistance of a glass bulk hydrated at 25° C as its outer surface was etched away, as shown in Fig. 12, for the same composition as glass number 1. As the outer layers are etched away, the resistance does not decrease measurably, suggesting a region of high ionic mobility. Then as etching continued there was a sharp drop in resistance suggesting a region of high resistivity. The distance from the surface of this high resistance layer is about at the depth at which one would expect the sharp changes in hydrogen and sodium concentration found in the present work. Then the resistance changed at an intermediate rate as etching continued into the unhydrated glass.

2. Hubbard *et al.* [8] found that glass number 1 swelled slightly after hydration at pHs from 2 to 7 at 80° C for 6 h. A soda-lime glass of composition (wt %) 72.1 SiO₂, 10.1 CaO, 13.5 Na₂O, 3.3 MgO, and 0.7 R₂O₃ showed no swelling.

3. In the present work hydrogen, probably in the form of water, was removed from the surface layers of glasses 1, 5 and 6 in vacuum at room

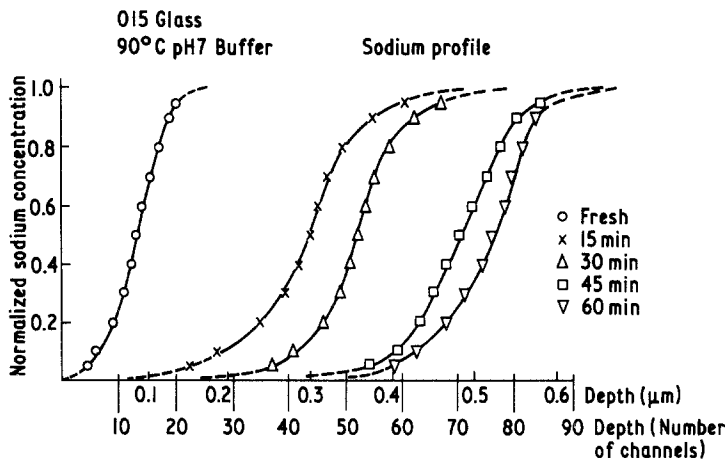

Figure 6 Profile of normalized sodium concentration as a function of depth in glass number 1 after different times of hydration at 90° C from Rutherford back-scattering.

temperature; there was no evidence for removal of hydrogen in glasses 4 and 7.

4. Surface layers of hydrated binary alkali silicate glasses show greater changes in the Si-O stretching region (9 to 11 μm) in infrared reflection than for soda-lime glass, and surface layers begin to peel from the binary glasses [9].

TABLE II Leaching depths of profiles of different ions in various glass after hydration in pH 7 buffer

Time of Hydration (min)	Depth (μm)		
	Hydrogen	Sodium	Calcium
<i>Glass number 1, 90°</i>			
15	0.21	0.21	*
30	0.31	0.27	*
45	0.38	0.39	*
60	0.46	0.44	*
180	0.83		*
260	~ 1.0		~ 0.013
1440	(2.2)		0.036
7200	(4.9)		0.053
<i>Glass number 1, 50°</i>			
45		0.09	*
240		0.16	*
900		0.33	*
1440			*
<i>Glass number 2, 90°</i>			
15	0.32	0.21	*
30		0.33	*
45	0.46		*
1200			~ 0.027
<i>Glass number 3, 90°</i>			
15	0.05	0.04	*
45	0.10		*
60		0.08	*
120	0.13		*
150		0.13	*
26000		1.1	

() extrapolated.

* ≤ 0.007.

These results suggest that after reaction with water the structure of a hydrated surface layer of glass can change, becoming more open, and that ionic mobilities in this layer are increased. To develop a diffusion model taking into account this layer, it is assumed that there is a sharp boundary between the transformed layer and the dry glass. The constituents of the layer are assumed to be in equilibrium with both the solution and the dry glass at this boundary. This assumption is consistent with the uniform ionic concentrations found in the transformed layer and also with measurements of Wikby [3] on the electrical potential across a hydrated glass bulb as its surface is etched away. The potential across the bulb was constant as the low resistance layer at the outer surface was etched away, and changed sharply when the high resistance layer was etched away. The constant potential from the surface through the transformed layer shows that this layer is in equilibrium with the solution and throughout its thickness because of rapid ionic mobilities within the layer.

Molecular water apparently does not diffuse into the layer except in association with a hydrogen ion as the hydronium ion, since the hydrogen content of the layer is no more than a factor of three greater than the sodium concentration.

At the boundary between the transformed layer and the dry glass there is equilibrium characteristic of the solution. Thus in the glasses studied here the alkali in the glass is completely or almost completely exchanged for hydrogen-bearing ions at this boundary. Interdiffusion between these ions takes place deeper into the glass in the same way as described in previous work [5].

This model is illustrated in Fig. 13, in which

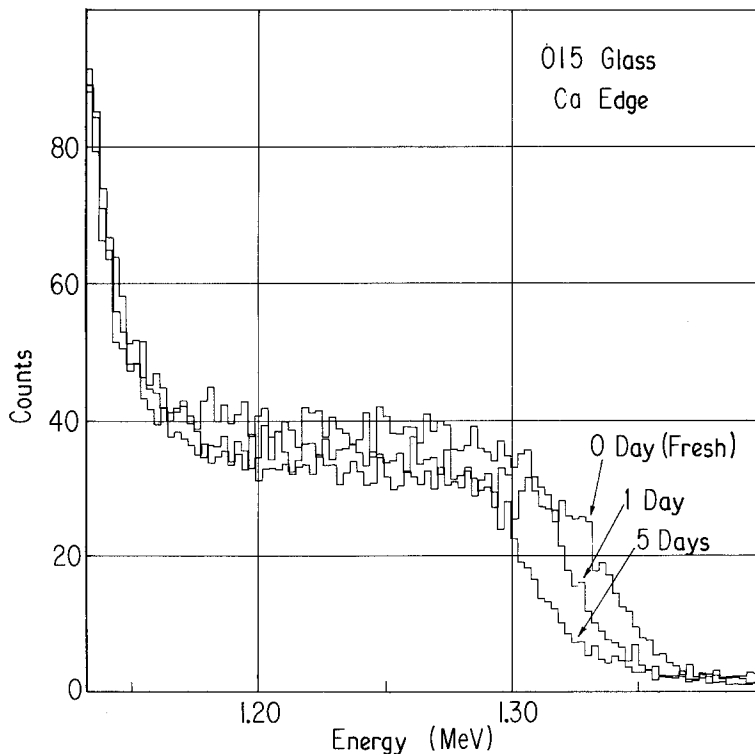

Figure 7 The calcium region (expanded) of a Rutherford backscattering spectrum for samples of glass 1 exposed to water at 90° C. Calcium depletion of 36 n is seen in an exposure of 1 day.

hydrogen profiles for glass no. 1 at different hydration times are superimposed. The transformed layer is assumed to extend from the outer surface to the solid vertical line. Further into the glass interdiffusion takes place with the interdiffusion coefficient [5]:

$$D = \frac{D_H D_A}{X_A D_A + X_H D_H} \quad (4)$$

where D_H and D_A are tracer diffusion coefficients for hydrogen-bearing and alkali ions, and X is the mole fracture of ions, $X_A + X_H = 1$. D_H and D_A can be functions of compositions; for simplicity they are assumed to be independent of concentration in this work. In Fig. 13 the profiles beyond the transformed layer is fit with Equation 4 and $D_A/D_H = 30$. The diffusion times were so short that surface dissolution of the glass was negligible.

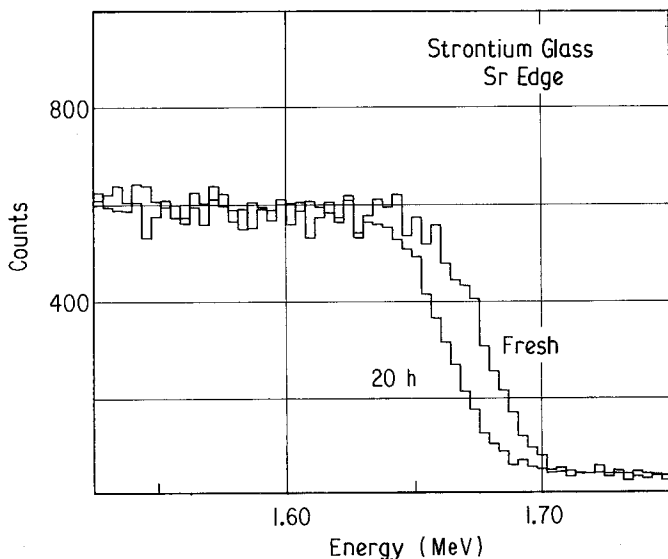

Figure 8 The strontium region (expanded) of a Rutherford backscattering spectrum for samples of glass 2 exposed to water at 90° C for 0 h and for 20 h. The strontium is depleted to depths of 25 n in 20 h.

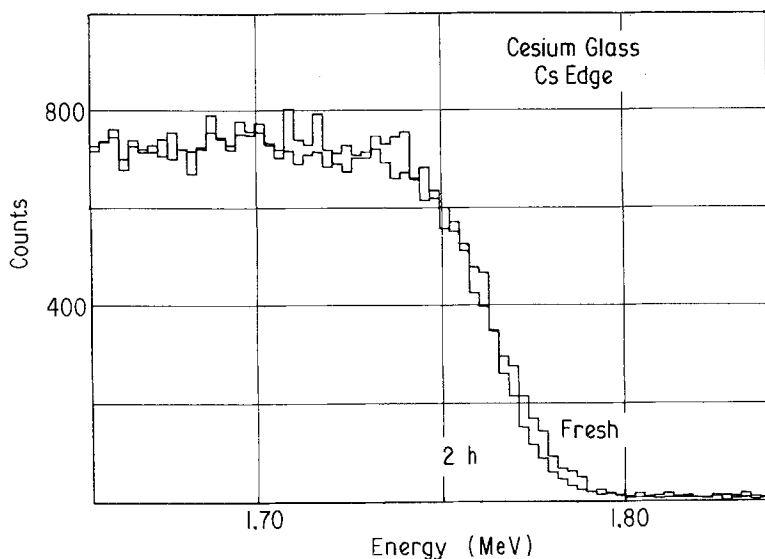

Figure 9 The caesium region (expanded) of a Rutherford backscattering spectrum for samples of glass 3 exposed to water at 90° C for 0 h and for 2 h. No caesium depletion is seen for 2 h exposure.

The diffusion coefficients calculated at 90° are given in Table III. The D_{Na} value is close to the values of about $1.3(10)^{-13} \text{ cm}^2 \text{ sec}^{-1}$ extrapolated from measurements by Johnson *et al.* [10] of tracer diffusion of sodium in a similar glass at 400° C, and from Wicby's measurement of conductivity of the dry glass at room temperature. In these extrapolations an activation energy of 63 kJ mol^{-1} was used.

The mobility ratio of 30 found above is also consistent with the measurements of electrical potential across a bulb of number 1 glass by Wikby [3]. The difference in potential before and after the removal of the high resistance layer was

about 86 mV. This potential should equal the diffusion potential set up in the glass by the interdiffusion of hydronium and sodium ions. Even after etching there is a surface (Donnan) potential between the solution and the glass, but the interdiffusion layer is etched away so rapidly that the diffusion potential is not set up. The equation for the diffusion potential is [11]:

$$V_D = \frac{RT}{F} \ln \frac{D_A}{D_H} \quad (5)$$

where F is the Faraday. Equation 5 is valid when the hydronium–sodium exchange is complete at one boundary and there are only sodium ions deep into the glass. From Equation 5 and with a potential of 86 mV, $D_A/D_H = 28$, well

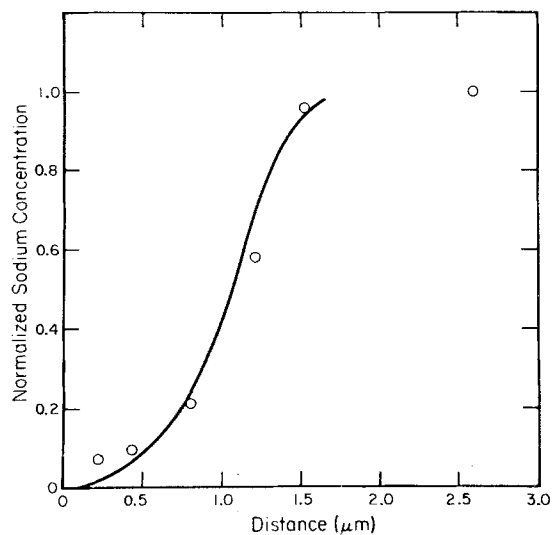

Figure 10 Profile of sodium in glass number 3 as determined by chemical etching and analysis.

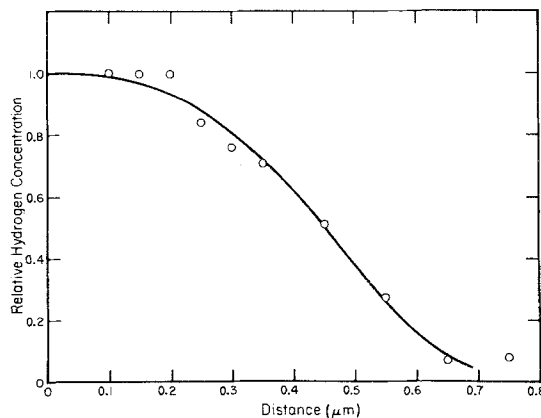

Figure 11 Profile of hydrogen in glass number 4 after hydration for 30 min in water at 90° C, from nuclear resonant analysis. Line from Equation 4 with $D_A/D_H = 50$.

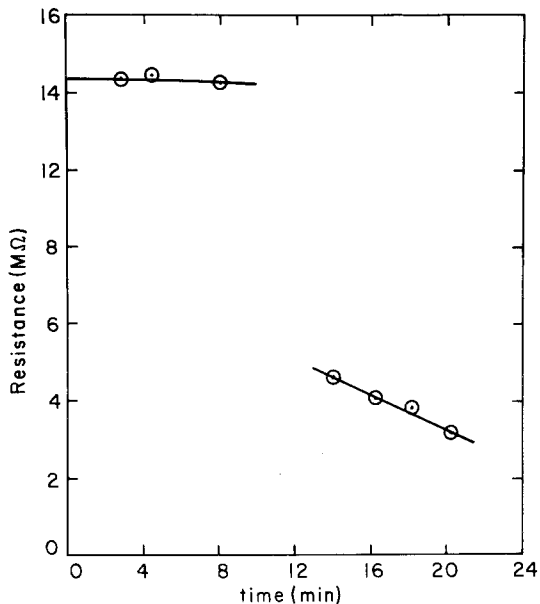

Figure 12 Resistance of glass number 1 after hydration for 220 h at 25°C in carbonate buffer at pH 7 as it was etched away in 0.3% HF [3].

within the error of fitting to the ratio of 30 in Fig. 10.

Profiles of ions in glasses 3 and 4 can be fit without assuming a transformed layer, as shown in Figs. 7 and 8. The mobility ratios are 100 and 50 in these fits, and the calculated diffusion coefficients are given in Table III. The profile in glass 3 shown in Fig. 7 was measured after 18 days, so it is likely that it was in the steady-state, where the penetration depth y is constant and for $D_A/D_H = 100$ is given by:

$$y = 4.5 D_H/v \quad (6)$$

where v is the velocity of dissolution of the glass.

For glass 3, v was measured to be $3(10)^{-11}$ cm sec^{-1} ; then the value of D_H as given in Table III was calculated.

Hydrogen profiles in glass number 1 were also measured at 50°, giving a slope of X against $t^{1/2}$ of $1.42(10)^{-7}$ cm $\text{sec}^{-1/2}$ as compared to a slope of $7.36(10)^{-7}$ cm $\text{sec}^{-1/2}$ at 90°. These values give an activation energy of about 80 J mol^{-1} .

5. Discussion

The good fit between the model and experimental profiles confirm the presence and importance of a transformed surface layer in less durable alkali silicate glasses. The separation between durable and non-durable alkali-silicate glasses depends upon whether or not they form such a layer. The good agreement between D_{Na} values calculated from the entire profile for glass number 7 [1] and the D_{Na} value calculated from the electrical resistivity of the glass shows that for this glass there is no transformed layer. In the same way the D_{Na} value in Table III for glass number 3 is about what would be expected for this glass, Terai [12] found that a ratio of 0.9 sodium to caesium ions reduced the sodium mobility about a factory of three from the mobility in the same glass with only sodium as alkali ions. Thus a D_{Na} of about $5(10)^{-14}$ cm² sec^{-1} is expected for glass 3, close to the value found, so there is apparently no transformed layer formed in glass number 3. There is no D_{Li} value available to compare with the calculated D_{Li} value for glass number 4 as given in Table III, but the low D_{Li}/D_H ratio and value D_{Li} probably indicate the absence of transformed layer in this glass also.

These results suggest that glasses 3, 4 and 7 have no transformed layers and are durable in

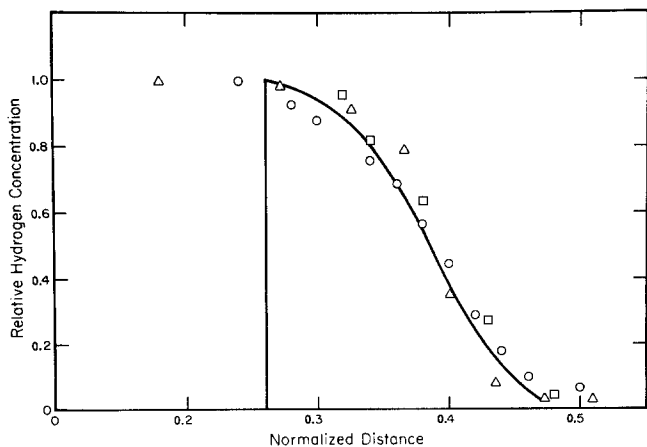

Figure 13 Profiles of relative hydrogen concentration in glass number 1 as a function of normalized distance, after hydration at 90° in pH 7 buffer for times in minutes: Δ , 15; \circ , 45; \square , 120. Vertical line, boundary between transformed layer and untransformed glass. Solid profile from Equation 4 with $D_A/D_H = 30$.

TABLE III Diffusion coefficients calculated from measured profiles at 90° C

Glass	A	D_A/D_H	D_H ($\text{cm}^2 \text{sec}^{-1}$)	D_A ($\text{cm}^2 \text{sec}^{-1}$)	Figure	Transformed layer
1	Na	30	$9(10)^{-15}$	$2.8(10)^{-13}$	10	Yes
3	Na	100	$7(10)^{-16}$	$7(10)^{-14}$	7	No
4	Li	50	$3.0(10)^{-15}$	$1.5(10)^{-13}$	8	No

that they react slowly with water. On the other hand glasses 1, 2, 5 and 6 have such layers, react more rapidly with water, and are therefore less durable. Hydrogen was removed from glasses 1, 2, 5 and 6 in vacuum at room temperature, whereas there was no evidence for desorption of water under these conditions for glasses 3, 4 and 7. These results are consistent with the presence or absence of transformed layers on these glasses.

Rana and Douglas [13] compared diffusion coefficients calculated from the rate at which sodium ions were leached from glass to those calculated from the electrical conductivity and the Einstein equation, as shown in Table IV. In the leaching calculation they assumed a constant diffusion coefficient. The D_{Na} values from the electrical conductivity should be characteristic of unhydrated glass. All the compositions in Table IV showed more rapid leaching than expected, particularly if the process was actually interdiffusion with $D_H < D_{Na}$. These results suggest that all the glasses in Table IV had transformed layers, and that these layers made up different fractions of the hydrated layer, giving different effective rates of interdiffusion. For glass number 1 of the present study the ratio comparable to those in Table IV is about two.

What factors cause or prevent formation of a transformed layer? Only a tentative answer can be given. Tomozawa and Capella [2] have found that the surface of a binary sodium silicate glass shows increased small angle X-ray scattering after hydration. They interpreted this increase to result from separation of the surface layer into two

phases on a fine scale ($< 10 \text{ nm}$). A transformation of the hydrated surface layer to two phases might give a continuous phase in which the ionic mobilities are higher. The transformation to this two-phase structure could be prevented by the presence of certain constituents of the glass. Thus the traditional increase of durability of silicate glasses when a small amount (about 2%) of alumina is added could result from the prevention of phase separation in the hydrated layer by the alumina. Alumina is known to reduce strongly the tendency to phase separation in silicate glasses. Glass number 7, a commercial soda-lime silicate, contained about 1.4% Al_2O_3 , which may be the reason that it does not have a transformed layer, whereas other soda-lime compositions such as glass 1 and 2 and the glass in Table IV do form these layers. CaO seems to reduce the tendency to form a transformed layer but not to prevent it. Only a small amount of caesium in glass number 3 appears to prevent formation of the transformed layer.

Since the first process in the reaction of water with glass is the interdiffusion of hydronium and alkali ions, it is natural to expect glass constituents that influence alkali diffusion to influence the rate of reaction with water. Calcium oxide reduces the diffusion coefficient of sodium in a glass, and part of the durability of soda-lime glasses results from this reduction. However, Table IV suggests that there is an optimum addition of calcium of about 10%; at higher calcium concentration the rate of interdiffusion becomes much faster. This result is contrary to the influence of calcium on sodium mobility in dry glass, which continues to decrease up to addition of at least 30% CaO [14]. Apparently layer formation is suppressed most effectively at 10% CaO; at higher calcium concentration a thicker layer forms.

Das and Douglas [15] studied the influence of third components on the rate of interdiffusion of sodium and hydronium ions. They found the greatest reduction with addition of 5% of aluminum, zinc, lead, titanium and zirconium oxides to 80% SiO_2 , 15% Na_2O glass, whereas the

TABLE IV Ratio of diffusion coefficients from reaction of water to those calculated from the electrical conductivity at 84° C, from [14]

Glass (mol %)			Ratio $D(\text{reaction})/D_{Na}$
SiO_2	NaO	CaO	
85	15		72
80	15	5	41
75	15	10	2.6
70	15	15	590

reduction was less for 5% of cadmium, magnesium, calcium, strontium, barium, and copper oxides. Except for zinc the stronger effect was with three or four valent oxides compared to divalent oxides. These effects do not correspond with changes to sodium mobility, which is not influenced much by aluminum or zinc additions but is strongly reduced by alkaline earths [15]. It appears that higher valent ions suppress transformation of the surface layer.

Lanford and Burman [16] found that saturated salt solution increases the rate of dissolution of glass number 7 in water by two or three orders of magnitude compared to the rate in pure water. It seems likely that the concentrated salt solution causes the surface layer on this glass to transform, greatly increasing the rate of reaction with water.

The surface layer on a hydrated glass is often called a "gel" layer. The present work shows that some alkali layers do not change structure in a surface hydrated layer, whereas on other hydrated glasses surface layers transform to a different structure that is expanded, perhaps as the result of increased stress in the surface caused by the replacement of sodium ions 0.1 nm in radius by larger hydronium ions 0.13 nm in radius. However, there is no evidence that this layer is a gel, or that Reaction 2 takes place to any appreciable extent, although a few bonds might be broken by this reaction and could assist the transformation. Thus the term "gel layer" is not appropriate to the transformed layer on the surface of a silicate glass.

The present work shows that there is only a small amount of preferential leaching of calcium or strontium from the glasses examined. We found much more preferential leaching of calcium when the glass was etched with HF, and other workers have reported substantial amounts of preferential calcium removal from profiles measured on sputtered glass surfaces. It seems likely that HF

treatment and sputtering preferentially remove calcium from the glass surface, and that therefore these techniques are not reliable for obtaining calcium profiles in glass.

Acknowledgement

This work was supported by the Materials Program, National Science Foundation, Grant no. DMR-8006091 at Rensselaer and by the Office of Naval Research at SUNY, Albany.

References

1. W. A. LANFORD, K. DAVIS, P. LAMARCHE, T. LAURSEN, R. GROLEAU and R. H. DOREMUS, *J. Noncryst. Solids* **33** (1979) 249.
2. M. TOMOZAWA and S. CAPELLA, to be published.
3. A. WIKBY, *Electrochimica Acta* **19** (1974) 329.
4. Z. BOKSAY, G. BOUQUET and S. DOBOS, *Phys. Chem. Glasses* **9** (1968) 69.
5. R. H. DOREMUS, *J. Noncryst. Solids* **19** (1975) 137.
6. J. ZIEGLER *et al.*, *Nucl. Inst. Meth.* **149** (1978) 19.
7. Y. MEHROTRA, PhD thesis, Rensselaer Polytechnic Institute, Troy, New York (1981).
8. D. HUBBARD, E. H. HAMILTON and A. N. FINN, *J. Res. Nat. Bur. Stand.* **22** (1939) 339.
9. D. E. CLARK, M. F. DILMORE, E. C. ETHRIDGE and L. L. HENCH, *J. Amer. Ceram. Soc.* **59** (1976) 62.
10. J. R. JOHNSON, R. H. BRISTOW and H. H. BLAU, *ibid.* **34** (1951) 165.
11. R. H. DOREMUS, in "Glass Electrodes for Hydrogen and Other Cations", edited by G. Eisenman (M. Dekker, New York, 1967) p. 101ff.
12. R. TERAJ, *J. Noncryst. Solids* **6** (1971) 121.
13. M. A. RANA and R. W. DOUGLAS, *Phys. Chem. Glasses* **2** (1961) 196.
14. M. FULDA, *Sprechsall* **62** (1927) 653, 769, 789, 810, 831.
15. C. R. DAS and R. W. DOUGLAS, *Phys. Chem. Glasses* **8** (1967) 178.
16. W. A. LANGFORD and C. BURMAN, to be published.

Received 10 June

and accepted 16 July 1982